

CSE 260M / ESE 260
Intro. To Digital Logic & Computer Design

Bill Siever
&
Jim Feher

This week

- **Thursday:**
 - **Studio — Watch Piazza/Email for location change.**
 - **Expected to be 3rd floor Seigle Hall**
- **Expecting to return Hw 2 and 3 by next week**

Next week

- Mon/Tues: Fall break
- Hw #4 Due Wednesday - Don't wait until the last minute!!!
 - Hopefully < 3 hours work; All review and good test prep!
 - Autograde feedback in Gradescope to check your work / resubmit
- Exam 1: Thursday during class
 - Exam 1 page updated with some details

Review: Moore Machine Structure

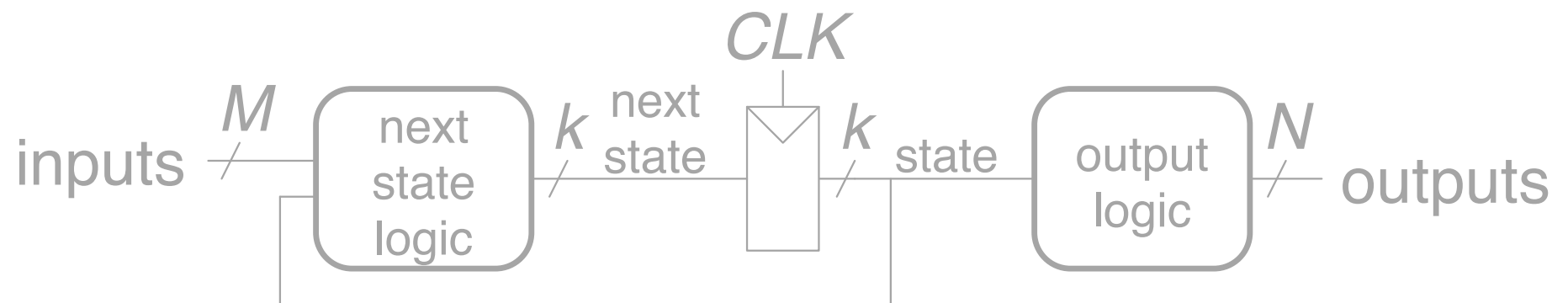

Review: Moore Machine Structure

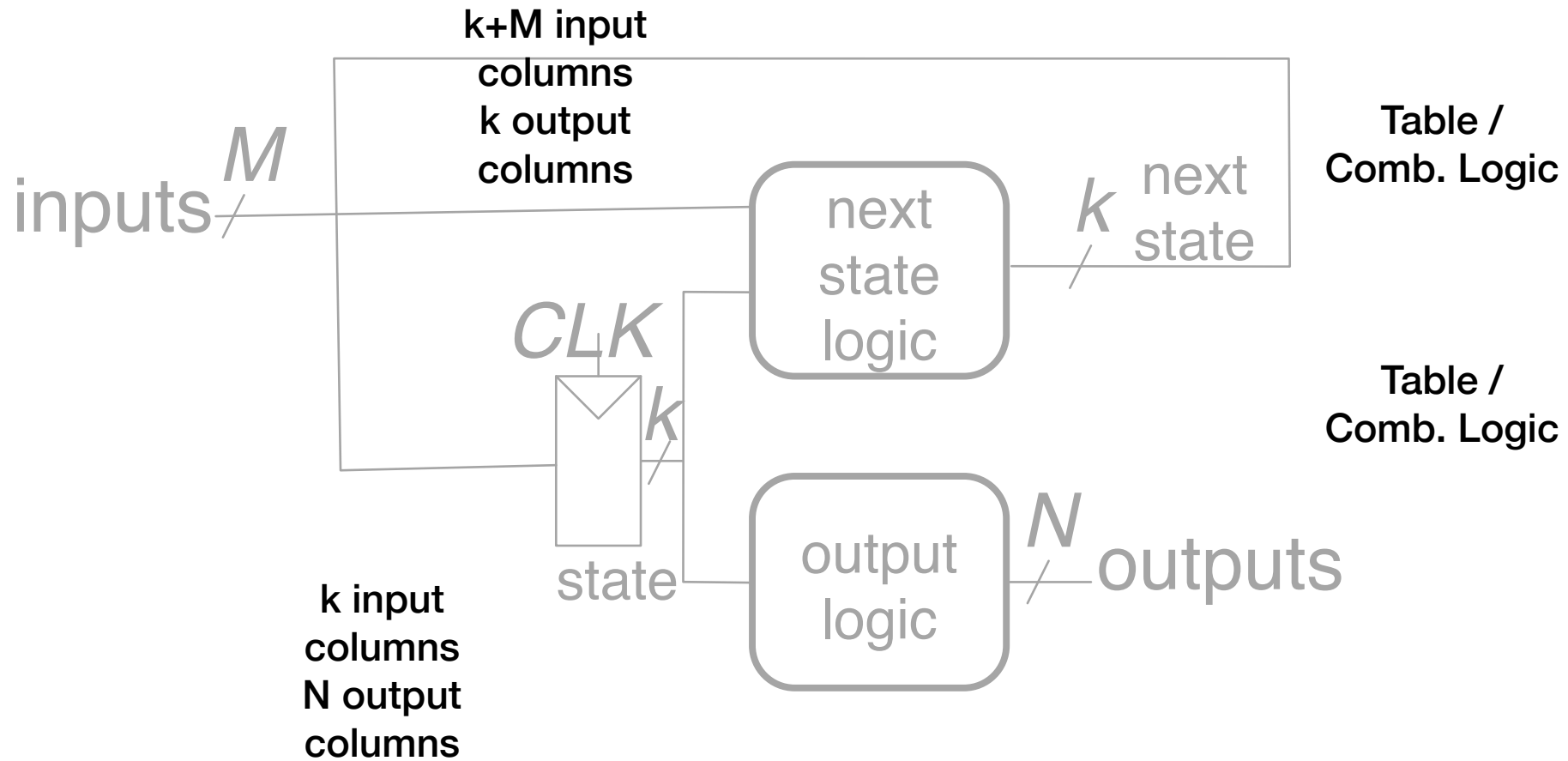

Studio Review

- SR-Latch: Hazardous conditions ahead!

Studio Review

- D-Flip Flop: First Gate Behavior
 - Provoking the SR Latch to fail by moving D around
 - We'll "watch" things of interest
 - Clock, D, nClock, nD, q1
 - And add "probes" to reset/set lines

D Flip Flop Time Parameters

- t_{setup} : Time D must be stable before clock
- t_{hold} : Time D must be stable after clock
- t_a : Aperture time ($t_{setup} + t_{hold}$) —
total window of time D needs to be stable around clock

Dff: Setup & Hold Time

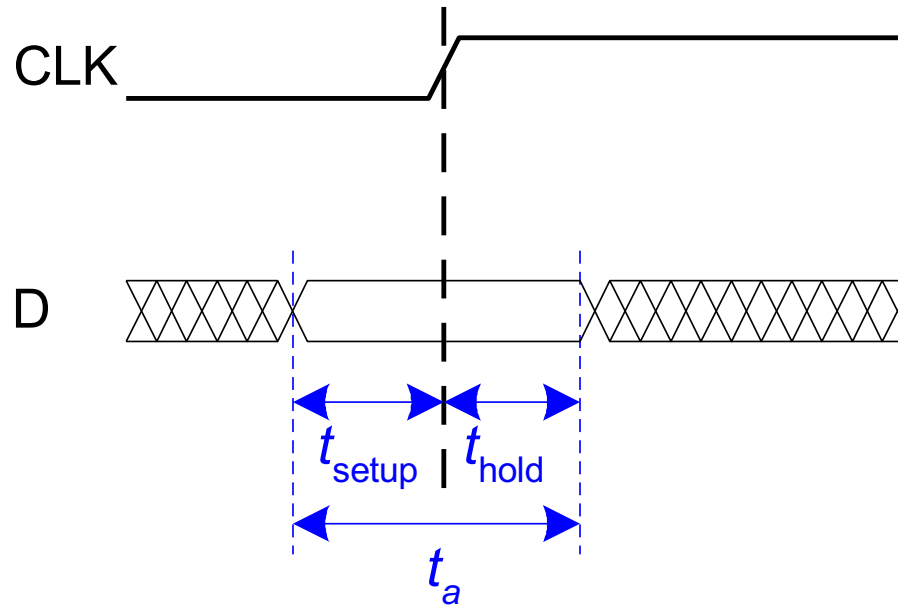

Dff Time Parameters

- t_{pcq} : Propagation delay from Clock to Q (pcq)
- t_{ccq} : Contamination delay from C to Q (ccq)

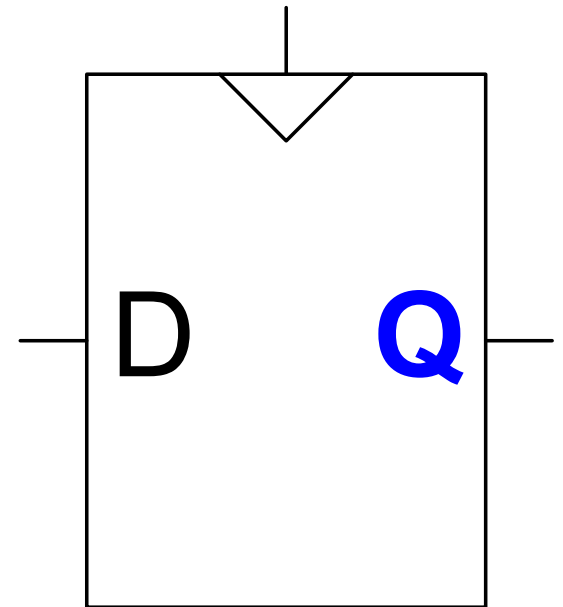

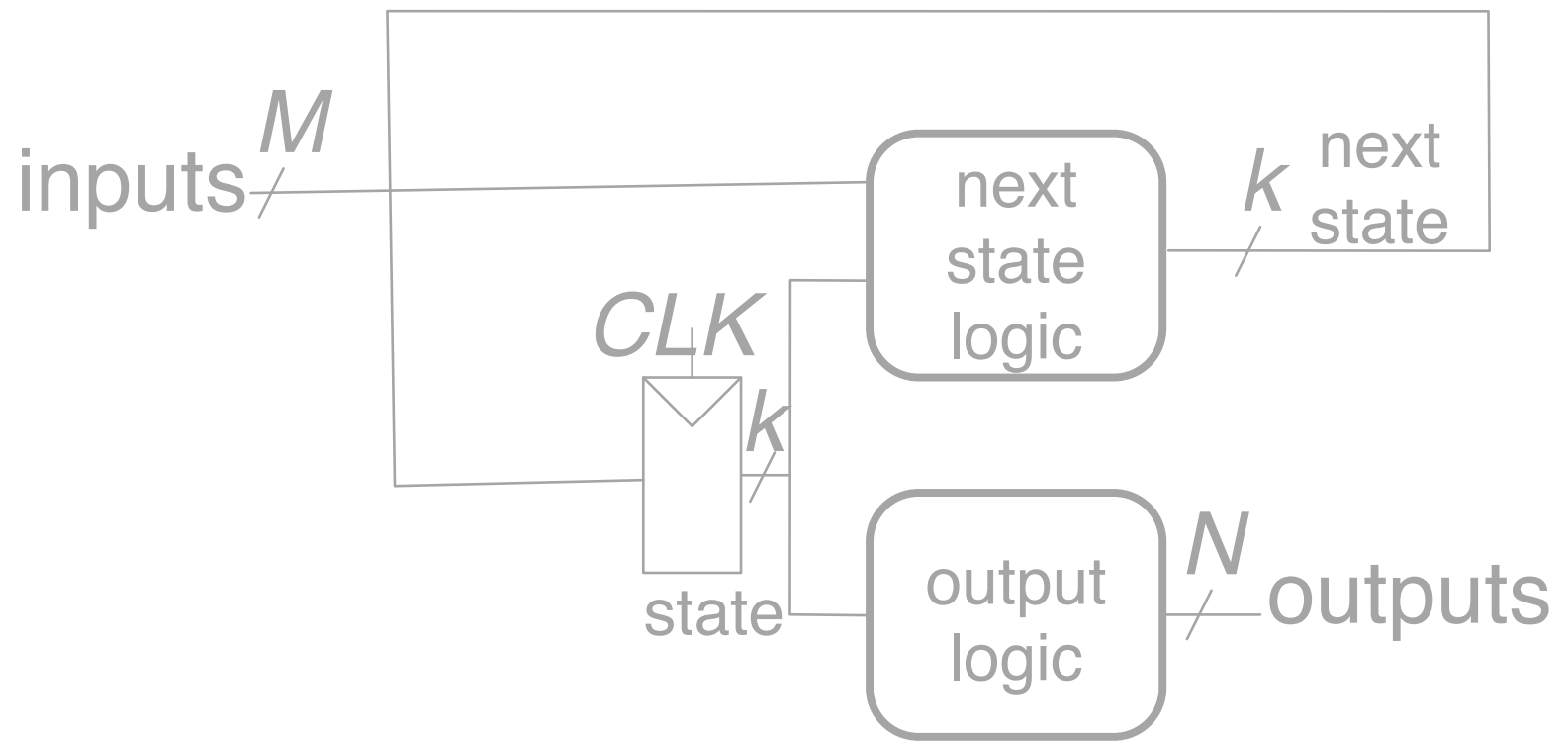

Setup Time Constraint

- Max time from R1 through CL
- R2's input needs to be stable t_{setup} before clock

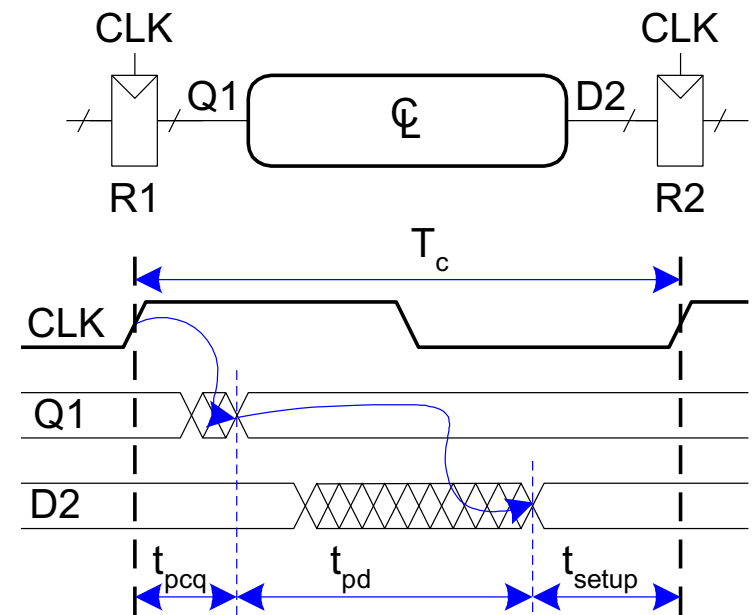

Setup Time Constraint

- Max time from R1 through CL
- R2's input needs to be stable t_{setup} before clock

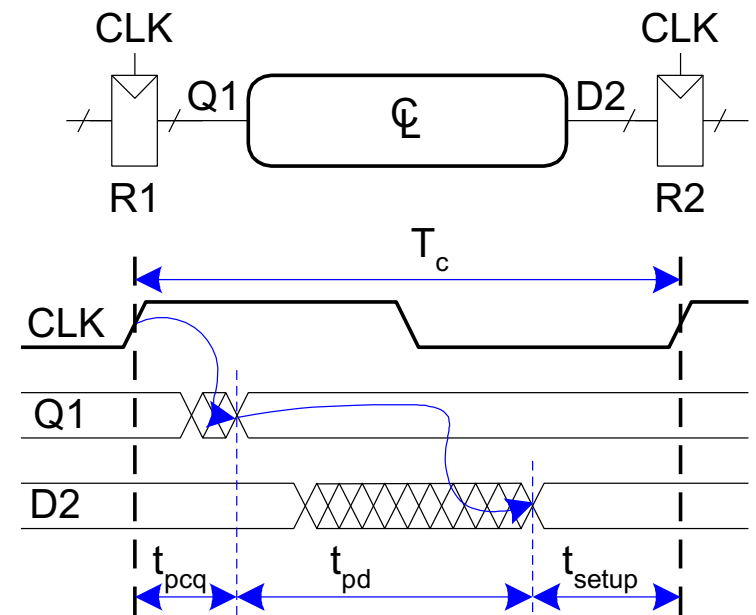

Hold Time Constraint

- Min time from R1 through CL
- R2's input must be stable t_{hold} after the clock

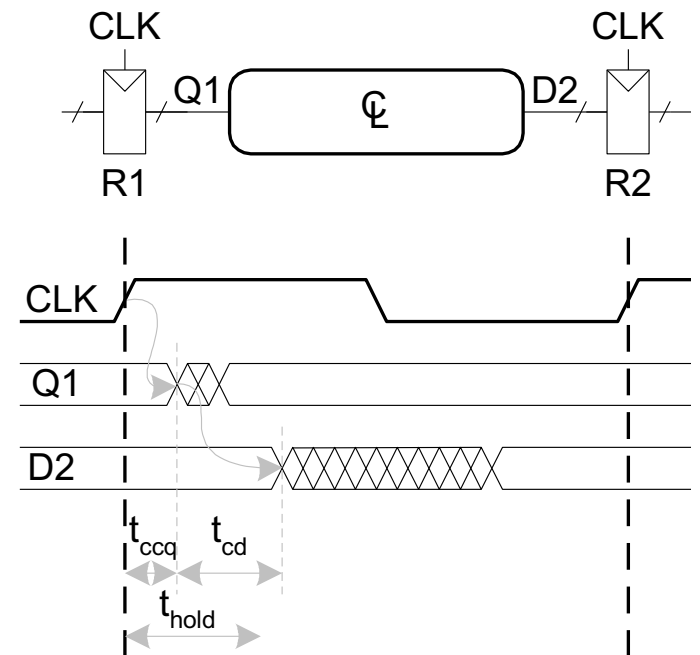

Hold Time Constraint

- Min time from R1 through CL
- R2's input must be stable t_{hold} after the clock

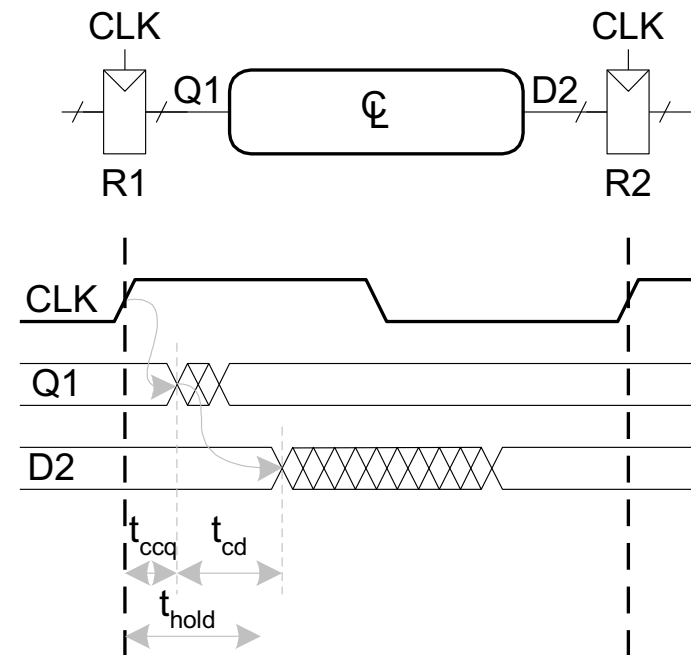

Synchronous Timing

- Must meet both
 - Setup Time Constraint
 - Hold Time Constraint

Chapter 4

Hardware Description Languages (HDLs)

- Specifies logic function only
- Computer-aided design (CAD) tool produces or synthesizes the optimized gates
- Most commercial designs built using HDLs

VHDL

- VHDL 2008
- Developed in 1981 by the Department of Defense
- IEEE standard (1076) in 1987
- Updated in 2008 (IEEE STD 1076-2008)

(System) Verilog

- Developed in 1984 by Gateway Design Automation
- IEEE standard (1364) in 1995
- Extended in 2005 (IEEE STD 1800-2009)

HDL

- A HDL is not a computer program.
- A HDL is not a computer program!
- A HDL is *not* a computer program!
- A HDL is *not* a computer program!
- A HDL is **NOT** a computer program!

HDL

- HDL is a way to *describe* hardware
- HDLs typically can describe hardware in different ways
- HDLs describe hardware in modules

(System) Verilog Module Example

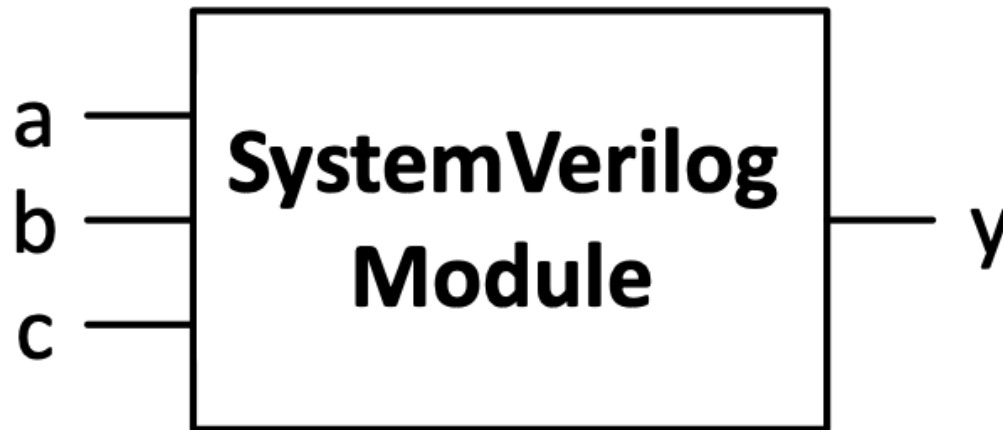

(System) Verilog Module Example

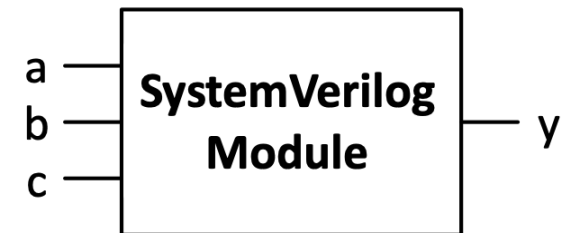

```
module example(input  logic a, b, c,  
               output logic y);  
    // module body goes here  
endmodule
```

(System) Verilog

- Case sensitive
- Identifiers follow rules like in programming languages
 - Ex: 2inputGate not allowed, but gateWithTwoInputs is.
- Whitespace ignored
- C/Java Style comments:
 - // Comment to end of line
 - /*
Block Comment
*/

(System) Verilog

- Basic logic operators
 - Binary: &, |, ^
 - Unary: ~

HDL: *Structural* (Verilog)

```
module nand3(input  logic a, b, c
             output logic y);
    logic n1;                // internal signal

    and3 andgate(a, b, c, n1); // instance of and3
    inv  inverter(n1, y);      // instance of inv
endmodule
```

HDL: *Structural* (Verilog)

```
module nand3(input  logic a, b, c
             output logic y);
    logic n1;                // internal signal

    inv  inverter(n1, y);    // instance of inv
    and3 andgate(a, b, c, n1); // instance of and3
endmodule
```

HDL: *Behavioral* (Verilog)

```
module nand3(input  logic a, b, c
             output logic y);
    assign y = ~(a & b & c);
endmodule
```

(System) Verilog

- Multi-bit values: Array-like notation with bit ordering:
`logic [7:0] a;`
- Multi-bit reductions by pre-fix notation on multi-bit values
`assign y = &a;`

(System) Verilog

- Conditionals via Ternary operator (? :)

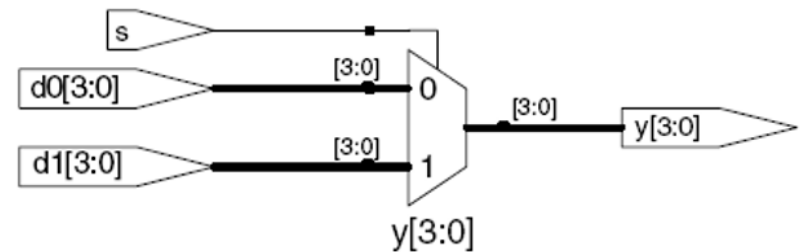

```
module mux2(input logic [3:0] d0, d1,  
            input logic s,  
            output logic [3:0] y);  
    assign y = s ? d1 : d0;  
endmodule
```

Operator Precedence

~	NOT
*, /, %	mult, div, mod
+, -	add, sub
<<, >>	shift
<<<, >>>	arithmetic shift
<, <=,	comparison
==, !=	equal, not equal
&, ~&	AND, NAND
^, ~^	XOR, XNOR
, ~	OR, NOR
?:	ternary

Number Formats

Number	# Bits	Base	Decimal	Stored
3'b101	3	binary	5	101
'b11	unsized	binary	3	00...0011
8'b11	8	binary	3	00000011
8'b1010_1011	8	binary	171	10101011
3'd6	3	decimal	6	110
6'o42	6	octal	34	100010
8'hAB	8	hexadecimal	171	10101011
42	Unsized	decimal	42	00...0101010

Verilog Bit Manipulations

- Subscripting and grouping

```
assign y = {a[2:1], {3{b[0]}}, a[0], 6'b100_010};
```

- Underscores can be used for clarity

Questions

- What about the exam????
- Will we use a HDL?
- [Which HDL?]
- How big will our circuits/computers get?
- What's synthesis? Are there things that can't be synthesized?
- Is my degree worth it? (I think mine was. Your mileage may vary...)

Next Time

- Studio
- Homework 4 due next Wed night!